



**Broadcast Devices, Inc.**

***ATB-300 Audio Tool Box***  
***\*Digital/Analog Audio Switcher DA***

**Operations Quick Start Guide**

**Broadcast Devices, Inc.**

**Tel. (914) 737-5032**

**Fax. (914) 736-6916**

**World Wide Web: [www.Broadcast-Devices.com](http://www.Broadcast-Devices.com)**

**Rev H. 01/20**

**\*Option Dependent**

## Table of Contents

I.	Basic Description	3
II.	ATB-300 Operational Mode Descriptions	3 – 7
	A. Memory Programming	4
	B. Silence Interval Programming	4
	C. Silence Threshold Programming	5
III.	Remote Control Operation	7-8
IV.	Input Mode Selection Menu System	8 - 9
V.	Audio I/O Connector Diagrams	10 - 11
VI.	Remote Control Connector Diagrams	12
VII.	Audio Status Output GPO Connection Diagram	13
VIII.	Frame Rate Conversion Information	14
IX.	Ethernet Setup	15-17
X.	Warranty	18

## **I. Basic Description**

Basic Description by model number:

ATB-300-1 4 – AES I/O Digital only switcher/router  
ATB-300-2 4 – AES I/O and 4 -analog L/R input switcher/router  
ATB-300-3 4 - AES I/O and 4 - analog L/R output switcher/router  
ATB-300-4 4 – Analog only I/O  
ATB-300-5 4 - AES I/O, 4 – analog L/R balanced I/O  
ATB-300-6 8 – AES I/O  
ATB-300-7 8 – Analog Input 4 Analog Output  
ATB-300-8 8 – Analog I/O  
ATB-300-9 4 AES I/O 4 Composite baseband I/O  
ATB-300-10 4 Analog L/R, 4 – Composite baseband I/O

ATB-300 is a 4 or 8 channel stereo analog / digital audio switcher/distribution system featuring silence detection and automatic switching. Input and output types are defined by the model number as shown above. The ATB-300 can be used to manually switch inputs or will automatically switch when a programmable silence interval of between 10 and 600 seconds is detected. Auto switching is programmed using a “priority list” of 4 or 8 memories depending on configuration which are programmed with input channels to search for audio in order of programmed preference. The ATB-300's intelligent search algorithm constantly monitors all inputs to allow immediate switching to the first active channel in the priority list without need to sequence through inactive channels when silence is detected.

### **AES I/O module Description**

The AES I/O module allows for up to four AES inputs and outputs per module. All I/O through this module follow the AES3 standard for interface. All I/O are 110 ohm transformer coupled. The AES I/O module allows the user to select AES output clocks including 32, 44.1 and 48 KHz sampling by DIP switch selection. Factory default is 44.1 KHz.

### **Analog Input Module Description**

ATB-300 models with analog input are balanced bridging inputs capable of accepting nominal +4 dBm input.

### **Analog Output Module Description**

ATB-300 modules with analog output provide balanced stereo output capable of driving 600 ohm loads. Nominal level is +4 dBm output as the analog output is intended for monitor applications. Maximum output level of the analog output module is +18 dBm.

### **Composite I/O module Description**

When equipped with the composite I/O module the ATB-300 can be used to switch between AES and composite FM stereo inputs. All composite inputs are available as AES3 outputs and are also routed to a four output composite baseband DA. The ATB-300 incorporates a high quality DSP based stereo decoder to provide AES3 output replicas of the composite inputs. The output of the DA is selected by selecting one of the four available composite inputs 5-8. If an AES input is selected the composite output will remain on the last selected composite input. Composite input is designed to accept 3.5 V peak to peak composite base band audio consistent with 100% modulation corresponding to +/- 75 KHz FM deviation. Four identical isolated composite outputs are available at 3.5 V peak to peak level suitable for driving most composite input FM exciters.

## **II. ATB-300 Operational Mode Descriptions**

### **ATB-300 Manual Mode**

The ATB-300 defaults to MANUAL mode upon power up. The LCD display will indicate the manual mode as well as the currently selected input channel and the active / inactive status of that input on the top line. The lower line indicates the channel that will be switched to the outputs when the green ENTER (check mark) key is pressed. The UP and DOWN arrows are used to select the input channel. The activity status of that channel is also shown to avoid switching to an inactive channel. When the select key is pressed the new selection is stored to memory and the audio is switched. This setting is NON VOLATILE. If the ATB-300 is power cycled this channel will be selected on power up.

**Figure 1 - ATB-300 Manual Mode Display**

In manual mode the user may also program the priority memories, the silence interval and the relative audio threshold which triggers the active / inactive determination.

MANUAL CH1 SELECTED
INPUT: CH 1 NO AUDIO

## A. Memory Programming

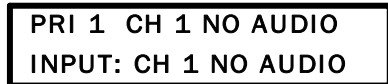

PRI 1 CH 1 NO AUDIO  
INPUT: CH 1 NO AUDIO

**Figure 2 - ATB-300 Priority Memory Programming Mode Display**

Pressing the F2/F5 key will enter the memory programming mode. In this mode, the top line of the LCD indicates the current memory (PRI 1 to PRI 8) being programmed, its contents and the activity status of that channel. The lower line indicates the channel that will be programmed into the memory when the ENTER key is pressed along with its activity status.

The LEFT and RIGHT ARROW keys are used to select a memory to program. The UP and DOWN keys sequence through the input channel selections. Pressing the ENTER key will program the channel indicated on the bottom line in to the priority memory. Note that programming the same channel into more than one memory is possible and can be done to avoid having an unconnected input in the priority memory list. The factory default memory channels are programmed to sequence through the 8 possible inputs in numerical order.

## B. Silence Interval Programming

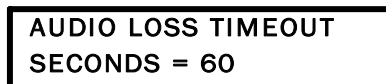

AUDIO LOSS TIMEOUT  
SECONDS = 60

**Figure 3 - ATB-300 Silence Interval Program Mode Display**

Pressing the F3/F6 Key will allow programming the silence interval. Select the desired interval using the UP and DOWN arrow keys. The interval can be set to any time between 10 and 600 seconds (Default = 60 seconds) using the UP and DOWN arrow keys. Pushing the ENTER key will put this setting into non-volatile memory. Pushing the red X key will return to the original value before it was changed. NOTE: the ENTER key MUST be pushed to retain this setting after power is cycled. This allows the user to test a setting before committing it to memory.

### C. Silence Threshold Programming



OUTPUT LEVEL = -20 dBFS  
SILENCE LEVEL -55 dBFS

**Figure 4 - ATB-300 Silence Threshold Programming Mode Display**

Pressing the F3/F6 Key again will allow programming of the silence threshold level. The upper line of the LCD indicates the level of the input currently selected channel. The lower line indicates the current threshold below which a channel will be considered INACTIVE. This level can be set to any level between -30 to -55dbFS (default= -55dbFS) using the ^ v keys. Pushing the ENTER Green Check Mark key will put this setting into non-volatile memory. Pushing the Red X key will return to the original value before it was changed. NOTE: the ENTER Green Check Mark key MUST be pushed to retain this setting after power is cycled. This allows the user to test a setting before committing it to memory. Note: ATB-300-9, 10 systems equipped with FM stereo base band composite modules will have a factory default of -40 dB FS due to the inherently higher noise level in composite systems. Manual operation is also available using the rear panel remote connections. See “Remote Operation” for details.

### ATB-300 Auto Mode

Pushing the F1/F4 key will alternate between the manual and auto modes. In auto mode the display will indicate the currently selected channel and its activity status. The lower line indicates the status of the priority memories and the activity status of the input channel programmed into them. Pushing the UP and DOWN keys will allow previewing the contents of each priority memory.

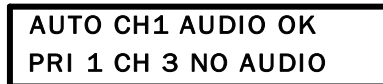

AUTO CH1 AUDIO OK  
PRI 1 CH 3 NO AUDIO

**Figure 5 - ATB-300 Auto Mode Display**

When the ATB-300 detects an audio level below the silence threshold for the pre selected time interval it will look at the priority memories and switch the lowest priority channel which is active to the output. The display will indicate a loss of audio on the top line of the LCD and will indicate the input which was switched to the output on the lower line along with its activity status. It will also close the fault detected relays contacts available on the rear panel remote connector. Pushing the red X key will reset the

warning as well as the relays. If the rear panel remote is enabled, an input is provided to do this using an external closure as well.



AUDIO LOSS DETECTED  
AUTO CH 5 AUDIO OK

**Figure 6 - ATB-300 Silence Detected Display**

Note that the ATB-300 is capable of detecting a subsequent loss of audio on the channel that was automatically selected. If such an event should occur, the priority list will again be used to select the first available active channel in the list.

### **Audio Restored Look Back Feature**

The ATB-300 has the ability to monitor the designated primary channel after a loss of audio has been detected by the silence sensor if the unit is in the automatic mode. If audio is restored to the primary channel after a user programmed number of minutes the unit will revert back to the primary channel automatically.

The factory default setting for the look back feature is disabled. To enable the look back feature follow the procedure below:

1. Place the unit in the manual mode by pressing F1
2. Toggle F3 until the display says AUTO RETURN FUNCTION – factory default is DISABLED.
3. Press the UP arrow to set the number of minutes the unit should wait before reverting back to the primary channel only after audio has been restored to the primary channel. The unit can wait from 1 to 60 minutes before reverting back to the primary channel.
4. Place the unit back into the AUTO mode by pressing F1 twice. The first press of F1 takes the unit out of the programming mode and into MANUAL. The second press of F1 places the unit back into AUTO mode.

### **III. REMOTE CONTROLLED OPERATION**

The ATB-300 provides remote inputs for channel selection via rear panel GPIO, via Ethernet by use of the BDI Stack GUI and for all ATB-300 units with S/N 211 or greater can utilize SNMP for use with SNMP enabled remote controls. The SNMP MIB is contained on the CD provided with the unit and is also available for download from the BDI web site under downloads. In addition to channel selection, to select between manual and auto modes, reset a fault warning, selection of an input and to enable/disable remote operation is also available via all three methods. Open collector

status outputs are provided to indicate the currently selected input channel for GPIO. These outputs are capable of sinking up to 100ma and are rated at a maximum of 30v DC.

To enable remote operation the REMOTE ENABLE input must be connected to the remote common (ground). Refer to page 12 Section VI. "ATB-300 Remote Connections" diagram for connection information.

The REMOTE AUTO or REMOTE AUTO inputs are used to select the switching mode by connecting the desired mode selection pin to remote common momentarily. To enable remote channel selection, the ATB-300 must be in MANUAL mode.

When the ATB-300 is in MANUAL mode, connecting a remote channel select input to remote common momentarily will cause the corresponding input to be selected as the current output. ONLY ONE channel select input can be active. If more than one input is selected simultaneously the ATB-300 will not switch.

#### **IV. Input Mode Selection Menu Operation**

The ATB-300 inputs can be configured for mode of operation on an individual basis. Stereo, Mono Left, Mono Right, L+R and Stereo Swap can be configured from the front panel. Use mono left and mono right to fill in a missing channel. For example; choosing mono left will take a signal only input on the left channel and apply it to both channels at the output of the unit. Use L+R to create a monaural input from a stereo source.

To select the input mode push F4 once. The display will indicate that you are in the INPUT MODE SELECTION menu. Select the input channel pair (1-8) using the up and down arrow keys. The left and right arrow keys are then used to select between the following modes:

##### **Press F4 once: Input Mode Selection**

Pushing the up arrow/down allows you to select the input channel to be changed:  
Pushing the left/right arrow buttons allows selection of the following input modes:

OFF

Stereo - Factory Default

LR Swap - L/R Channels Swapped

Mono L - L input fed to both L & R outputs

Mono R - R input fed to both L & R outputs

L + R - L & R inputs are summed and fed to both L & R outputs.

The input mode is automatically saved when selected. To exit this menu press the F1 key to return to the main menu.



### **Press F4 twice: Input Invert Control – Phase Inversion**

Pushing the up arrow/down allows you to select the input channel to be changed:  
Pushing the left/right arrow buttons allows selection of the following input modes:

Normal  
Invert Left  
Invert Right

Note: Phase inversion is Left or right but not both simultaneously.

Input Invert Control modes are automatically saved when selected. To exit this menu press the F1 key to return to the main menu.

### **Press F4 three times to enter Input Gain Control menu**

Pushing the up arrow/down allows you to select the input channel to be changed:  
Pushing the left/right arrow buttons allows you to adjust gain in one dB increments +/- 10 dB

### **Press F4 four times and the display will indicate Output Gain Control**

Pushing the up arrow/down allows you to select the output channel to be changed:  
Pushing the left/right arrow buttons allows you to adjust gain in one dB increments +/- 10 dB

Factory default for input and output gain controls is 0 dB. When factory default gains are used AES3 I/O is unity. When AES3 inputs are output to an analog channel the analog output will correspond to –10 dB below full scale AES3 input when AES3 input is nominal – 10 dB below full scale.

### **ATB-300 Factory Default Recovery**

As with any programmable device, it is possible that the user would like to quickly return to the “factory default” settings. To return the ATB-300 to its factory configuration remove AC power to the unit. While holding the red “X” key, restore AC power until the display indicates “FACTORY DEFAULT”.

# V. Audio I/O Connections

## ATB-300 Audio Connections

### DIGITAL AUDIO I/O

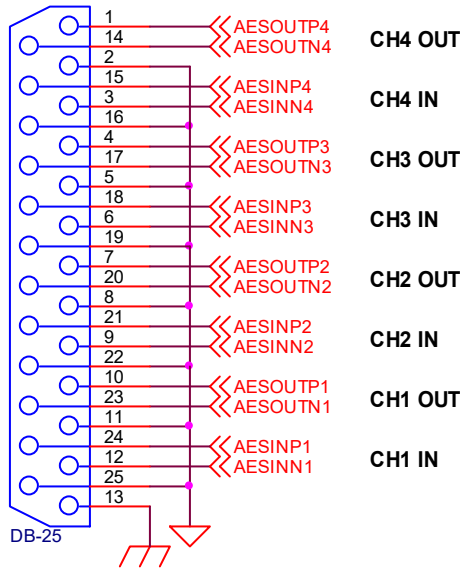

### ANALOG AUDIO - INPUT & OUTPUT PINOUTS ARE IDENTICAL

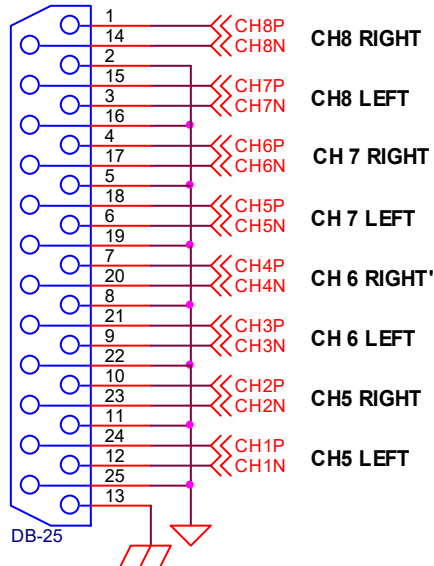

### ATB-300 AUDIO INPUT MAPPING – Dual AES Version

INPUT CHANNEL	TYPE	LOCATION
1	DIGITAL	AES 1
2	DIGITAL	AES 2
3	DIGITAL	AES 3
4	DIGITAL	AES 4
5	DIGITAL	AES 5
6	DIGITAL	AES 6
7	DIGITAL	AES 7
8	DIGITAL	AES 8

### ATB-300 AUDIO INPUT MAPPING – Hybrid AES/ANALOG Version

INPUT CHANNEL	TYPE	LOCATION
1	DIGITAL	AES 1
2	DIGITAL	AES 2
3	DIGITAL	AES 3
4	DIGITAL	AES 4
5	ANALOG	ANALOG IN 1-2 (L/R)
6	ANALOG	ANALOG IN 3-4 (L/R)
7	ANALOG	ANALOG IN 5-6 (L/R)
8	ANALOG	ANALOG IN 7-8 (L/R)
INPUT CHANNEL	TYPE	LOCATION
1	DIGITAL	AES 1
2	DIGITAL	AES 2
3	DIGITAL	AES 3
4	DIGITAL	AES 4
5	ANALOG	COMPOSITE BASE BAND 1
6	ANALOG	COMPOSITE BASE BAND 2
7	ANALOG	COMPOSITE BASE BAND 3
8	ANALOG	COMPOSITE BASE BAND 4

**Note:** BDI composite I/O interface panel connections should be made to analog inputs 5-8. This connector has all inputs and outputs grouped together for all analog composite I/O of the ATB-300. Note that while the panel designation is marked for 1-4 inputs that these are actually inputs 5-8 when viewed on the front panel display,

## VI. Remote Control Connections

### ATB-300 Remote Connections

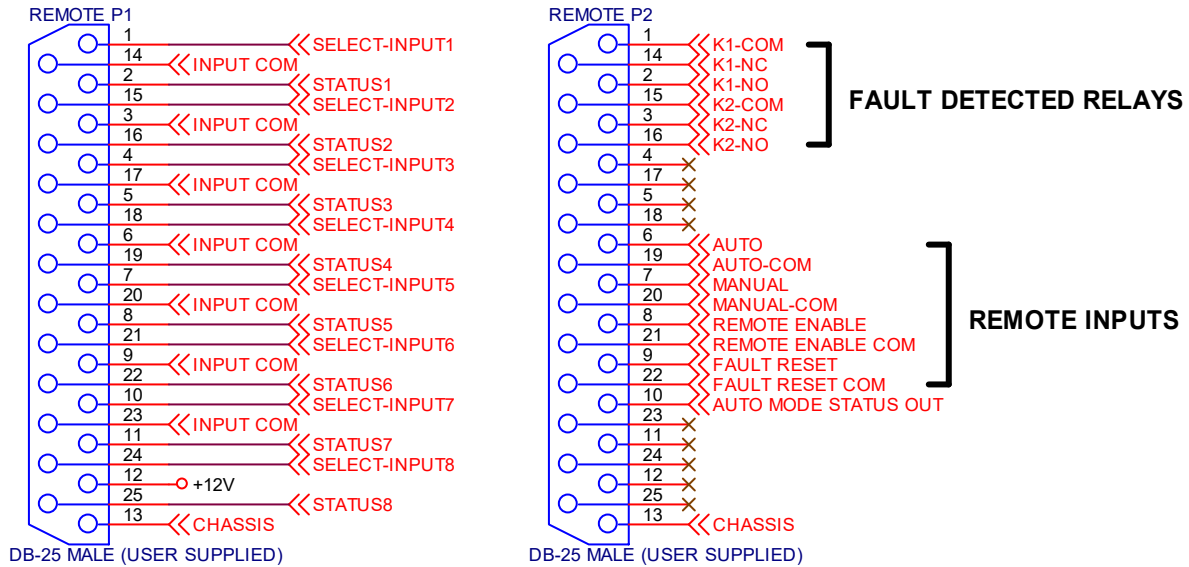

#### Notes:

1. Status outputs are open collector Darlington transistors capable of sinking 100ma @ 30v DC.
2. Select and remote inputs are momentary closures with internal 4.7K pullup resistors to 5v DC.

## VII. ATB-300 Audio Status

The ATB-300 provides audio status open collector outputs for each of the eight inputs. Each Output is held low when audio is present. If audio is removed for at least five seconds the respective channel will go to a high condition. If audio is restored for at least five seconds the respective channel go low.

On all ATB-300 versions the audio status connections shown above are available on the rear panel connection marked GPIO 2.

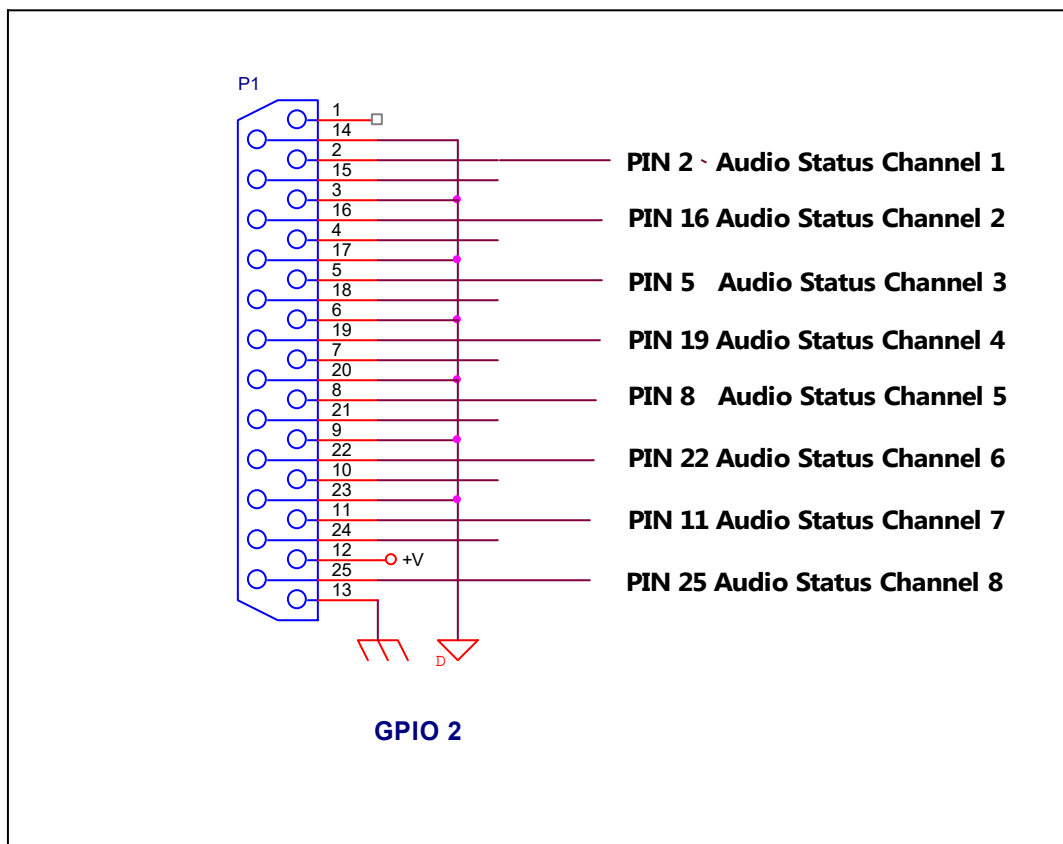

## VIII. Frame Rate Conversion Switch Selection

The ATB-300 has active frame rate conversion on all AES3 digital inputs. The unit can accept sample rates from 8 KHz to 96 KHz. The frame rate converter then up or down converts the sample rate to the selected sample rate. The ATB-300 is capable of outputting 32, 44.1 or 48 KHz sample rates. The factory default sample rate is 44.1 KHz. To change the sample rate to either 32 or 48 KHz refer to the diagram below. The sample rate converters are located on the AES I/O board. Locate S1 and change SR0, SR1 according to the chart below. Do not adjust any other DIP switch setting as this will result in incorrect operation of the ATB-300. Correct DIP switch settings are provided for convenience.

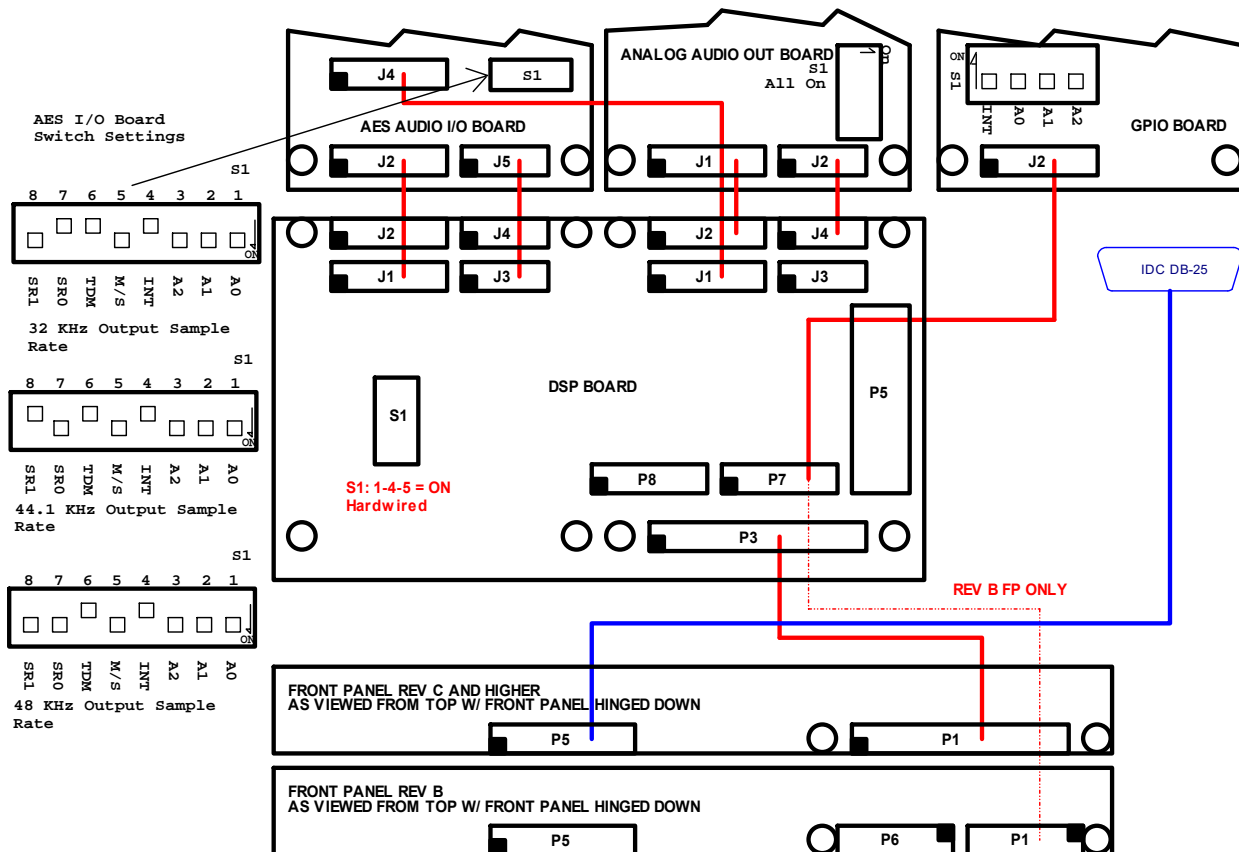

## IX. Ethernet Setup

The BDI Audio Toolbox series including the ATB, GPM and DAB versions of the product line now support Ethernet through use of BDI's BDI Stack Graphical User Interface. Now the Audio Toolbox series switchers can be remotely controlled and monitored via an Ethernet connection. All Audio Toolbox series products also provide standard GPIO interface for remote control as well.

### I. Ethernet Setup

**Prior to installation of the unit connect your unit to a router connection and then power cycle the unit to provide a 5 minute access window to the setup screen. Note that if you haven't connected to the unit within the 5 minute window you will lose access to the unit. This is a safety feature to prevent unauthorized changes to the IP configuration. Simply power cycle the unit again if you can't access the unit using a browser.** Using a browser enter the default IP address is: 192.168.1.150. Port 161 is default from the factory and can be reset but make certain that the new port is forwarded for external access if desired. After entering IP address through a standard browser and the screen below should appear:



The factory defaults are:

Username: username

Password: password

Use all lower case.

Once you enter the username and password click on the Green Arrow and the screen below should appear:

**bdi** www.broadcast-devices.com

### DAB-300 Setup

Firmware Revision: AUD L5.1.9, MAC: 54:10:EC:D9:C5:BC

Unit Name	User Name	Password
UnitName	username	password
SNMP Read Community	SNMP Write Community	SNMP Port
public	private	161
IP Address	IP Mask	Default Gateway
192.168.1.150	255.255.255.0	192.168.1.1
DNS		
192.168.1.1		

Save

Make the appropriate changes and to save them click the Green Check Mark Key. **We strongly recommend that your record the parameters changed here:**

NEW IP ADDRESS: \_\_\_\_\_

NEW IP MASK: \_\_\_\_\_

Primary DNS: \_\_\_\_\_

Gateway: \_\_\_\_\_

Serial Port Data: \_\_\_\_\_

Username: \_\_\_\_\_

Password: \_\_\_\_\_



**Make certain that for outside access to the unit that the serial data port chosen is forwarded on your router. If this is not done your computer will not be able to see the unit from outside of your router environment.**

Once you have made and recorded the changes to the IP environment power cycle the unit for the new parameters to take effect. **The new parameters only take effect after a power recycle.**

After power cycling the unit use the new IP address, username and password to enter the IP configuration screen to make sure that the parameters were accepted. Once you have successfully entered the IP configuration page the unit is now ready for use with the BDI Stack software provided on the CD packed with the unit and the Audio Toolbox Setup program that allow the user to name the inputs and outputs of the unit so that when the unit is accessed from the BDI Stack software that familiar names will appear making the unit easier to interpret. There are technical reference manuals for each program to guide you through the setup process.

### **SNMP Support**

All ATB-300 units starting with S/N 211 are SNMP agent v2 enabled. The unit can be remote controlled and monitored by use of the ATB Audio MIB file which is contained on the CD that was supplied with the unit. The MIB is also available from our web site on the download page. The MIB can be used with any SNMP enabled remote control and the unit can be setup for channel naming, unit name/location by use of a standard MIB browser.

## **X. Warranty**

Broadcast Devices, Inc. products are warranted against failure due to faulty materials or workmanship for a period of one year from the date of shipment to the ultimate user. The warranty covers repair or replacement of defective parts at the factory, provided the unit has been returned prepaid by the user. All shipments to the factory shall have affixed to the outside of the container a return authorization number obtained from the factory. The above warranty is void if the unit has been modified by the user outside of any recommendations from the factory or if the unit has been abused or operated outside of its electrical or environmental specifications. If customer conducted field tests suggest that the unit may be faulty, whether or not the unit is in warranty, a full report of the difficulty should be sent to Broadcast Devices, Inc. factory at Cortlandt Manor, New York. The office may suggest further tests or authorize return for factory evaluation.

Units sent to the factory should be well packed and shipped to Broadcast Devices, Inc. Check our website for current shipping address. Remember to affix the R.A. number to the outside of the carton. Any packages received without such R.A. number will be refused. Note: freight collect shipments will also be refused. When the unit has been received, inspected and tested, the customer will receive a report of the findings along with a quotation for recommended repairs, which are found falling outside of the standard warranty. Units returned for in-warranty repairs, which are found not to be defective will be subject to an evaluation and handling charge. In-warranty units will be repaired at no charge and returned via prepaid freight.

Out-of-warranty units needing repair require a purchase order and will be invoiced for parts, labor, and shipping charges.

When ordering replacement part, always specify A) Part Description, and Quantity; B) Date of Purchase, Where Purchased; C) Any Special Shipping Instructions. Always specify a street address, as shipping companies cannot deliver to a postal box.

Broadcast Devices, Inc. is not responsible for any other manufacturer's warranty on original equipment. Nor are we responsible for any failure, damage, or loss of property that may occur due to the installation or operation of our equipment outside of recommended specifications.

Broadcast Devices, Inc. reserves the right to change materials, specifications, and features from time to time.

[www.broadcast-devices.com](http://www.broadcast-devices.com)

Broadcast Devices, Inc.  
Email: [Customer.Service@broadcast-devices.com](mailto:Customer.Service@broadcast-devices.com)  
(914) 737-5032 Tel. (914) 736-6916 Fax.

